



SOLUTIONS INC

March 20, 2008

Dear Sir

As door and hardware professionals we are faced with enormous challenges. Declining margins and demanding customers are but some of the pressures eroding our profitability. At last there is an affordable software solution, designed for the door and hardware industry that is guaranteed to improve your firm's sales and administrative productivity. The Door Boss system automates the entire sales cycle. With our free 60-day trial, no up front costs and a pay as you go, we have removed all the risk.

- Quotations
- Shop drawings/hardware schedules.
- Purchasing.
- Change order management.
- Shipping bills.
- Invoices.
- Division 10

As a demonstration of the power of this system I have attached the documents for a fictitious project that I entered into the system in **19 minutes.** I invite you to sign up for the free 60 day trial at www.gerrisinc.com

Yours Truly

Gerry Muller
gerry@gerrisinc.com

Central Florida Door and Hardware

222 Sunshine way, Melburn FL, 345321 Tel 647-222-2525 Fax 647-222-2526

Contract quotation - job #29

Date: Mar 14,2008
Customer: Sunshine Contracting.
Project: Melburn ROI Inc. office addition
Prepared by: Gerry Muller

Attn: James

Hollow Metal

6 Frame(s)
7 Screen(s)
2 Door(s)

Supply only	\$ 3,189.89
	County tax \$ 127.60
	Total \$ 3,317.49

Note: Based on 18 Ga. doors, 18 ga KD frames and 16 ga. welded screens.

Wood

12 Door(s)

Supply only	\$ 2,941.50
	County tax \$ 117.66
	Total \$ 3,059.16

Note: Based on 5 ply oak doors with oak edges. All doors factory machined for hardware.

Finish Hardware

1 Continuous hinge * SL-11 83" * AL
3 Hinge * BB1168 4.5 x 4 NRP * 630
2 Closer * 4140 H-Cush * 689
4 Push Plate * CDH93A 5 x 20 * C32D
4 Closer * 1460 * 689
1 Sweep * W13S/36 * AL
1 Lock Set * AL80PD SAT 10=025 * 626
6 Lock Set * AL53PD SAT 10-025 * 626
5 Kick Plate * CDH92A 8 x 34.5 * C32D
4 Pull * CDH5109-1 * C32D
1 Threshold * CT10/36 * AL
13 Floor Stop * CDH212 * C26D
36 Hinge * BB1279 4.5 x 4 * C26D

- 2 Latchset * AL10S SAT 10-025 * 626
- 1 Weatherstrip * W2/17 * AL
- 1 Exit Device * 22EO * 689

Supply only	\$ 4,170.48
	County tax	\$ 166.82
	Total	\$ 4,337.30

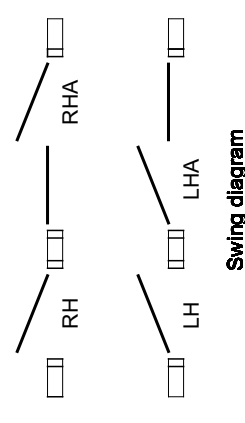
<p>General Notes</p> <p>Fabrication of materials shown will commence upon approval by the architect and receipt of approved hardware list.</p> <p>Doors and frames will be reinforced for surface mounted hardware as required. Drilling and tapping for surface hardware is by others. Doors and frames will be prepared and reinforced for mortised hardware. All holes will be tapped and drilled except for trim mounting holes.</p> <p>Doors and frames will be manufactured of zinc-coated steel touched up with zinc-rich primer, where zinc coating has been removed due to welding.</p> <p>Frames will be prepared for rubber bumpers.</p> <p>Note! General Contractor is responsible for frames and doors set plumb, square and level.</p>	<p>Miscellaneous Notes</p> <p>* Please verify swing at door #101</p> <p>* All oak doors to be 5 ply oak with oak edges c/w factory machining.</p>	<p>Abbreviations</p> <p>Dr.= door Fr.= frame Anch.= anchor Ga.= gauge Hcomb.= honeycomb core Poly.= polystyrene core Wd.= wood (door) Hm.= hollow metal Ps.= pressed steel De.= double egress RH= right hand LH= left hand RHR.= right hand reverse LHR.= left hand reverse Pr.= pair RHA.= right hand active LHA.= left hand active GPW.= Georgian polished wire (glass) D/I= dead lock 161 = govt. 161 lock prep. 86 = mortise lock prep. FB = flush bolt prep. s/bolt = surface bolt Reinf. = reinforcing S = reinf. for standard mount closer. PA = reinf. for parallel arm closer. TJ = reinf. for top j</p>
<p>Central Florida Door and Hardware 222 Sunshine way, Melburn FL 345321 Tel 647-222-2525 Fax 647-222-2526</p>	<p>Shop drawing</p>	<p>Swing diagram</p> 
<p>Project: Melburn ROI Inc. office addition Architect: ABC Design Inc. General Contractor: Sunshine Contracting. Date prepared: Mar 14, 2008</p>		<p>Sheet 1 of 6</p>

Op#	Arch#	Location	FRAMES						DOORS						Notes		
			Size	Elev	Series	Matl	Depth	Head	FR	Anchrs	Size	Elev	Series	Matl		Hand	Core
101	101	existing building to corridor 101	40X86	A	AS16	HM	5 3/4	2	.75 hr	Strap anchor	36X84X1 3/4	2G	LS18	HM	LHR	HComb	undersize door 3/16 for SL-11 continuous hinge
102	102	corridor 101 to office 102	60X86	C(L)	AS16	HM	5 3/4	2		Drywall Clips	36X84X1 3/4	F	A25	oak	LH	Particle	
103	103	Corridor 101 to office 103	60X86	C(L)	AS16	HM	5 3/4	2		Drywall Clips	36X84X1 3/4	F	A25	oak	RH	Particle	
104	104	Corridor 101 to office 104	60X86	C(L)	AS16	HM	5 3/4	2		Drywall Clips	36X84X1 3/4	F	A25	oak	LH	Particle	
105	105	Corridor 101 to office 105	60X86	C(L)	AS16	HM	5 3/4	2		Drywall Clips	36X84X1 3/4	F	A25	oak	RH	Particle	
106	106	Corridor 101 to office 106	60X86	C(L)	AS16	HM	5 3/4	2		Drywall Clips	36X84X1 3/4	F	A25	oak	LH	Particle	
107	107	Corridor 101 to office 107	60X86	C(L)	AS16	HM	5 3/4	2		Drywall Clips	36X84X1 3/4	F	A25	oak	RH	Particle	
109	109	Corridor 108 to lunch room 108	40X86	A	DW18	HM	5 5/8	2			36X84X1 3/4	G	A25	oak	LH	Particle	
110	110	corridor 108 to mens restroom 110	40X86	A	DW18	HM	5 5/8	2			36X84X1 3/4	F	A25	oak	LH	Particle	
111	111	corridor 108 to womens restroom 111	40X86	A	DW18	HM	5 5/8	2			36X84X1 3/4	F	A25	oak	RH	Particle	
112	112	Corridor 108 to storage 112	36X86	A	DW18	HM	5 5/8	2	.75 hr		32X84X1 3/4	F	A25	oak	LH	Particle	
113	113	Corridor 108 to boardroom 113	96X86	D(R) DBL	AS16	HM	5 3/4	2		Drywall Clips	36X84X1 3/4	FG	A25	oak	LHA/RH	Particle	
114	114	Corridor 108 to exterior	40X110	TRA	AS16	HM	8 3/4	2		Wire Masonry	36X84X1 3/4	NL	LS18	HM	RHR	PolyS	

Central Florida Door and Hardware

222 Sunshine way, Melburn FL 345321
Tel 647-222-2525 Fax 647-222-2526

Shop drawing

Project: Melburn ROI Inc. office addition
Architect: ABC Design Inc.
General Contractor: Sunshine Contracting.
Date prepared: Mar 14, 2008

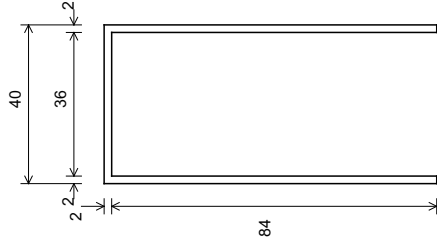

Elev A

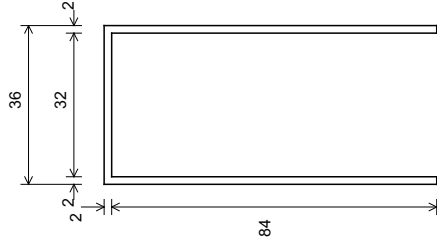

Elev A

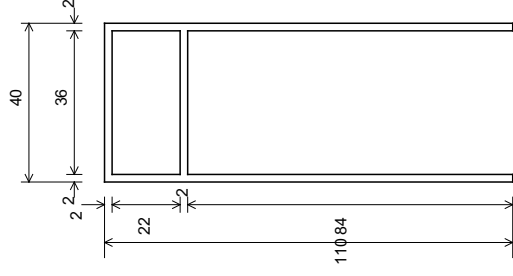

Elev TRA

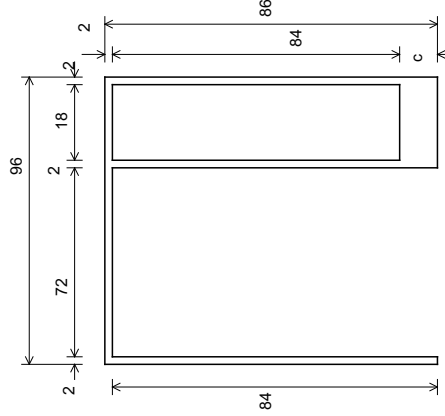

Elev D (R) DBL

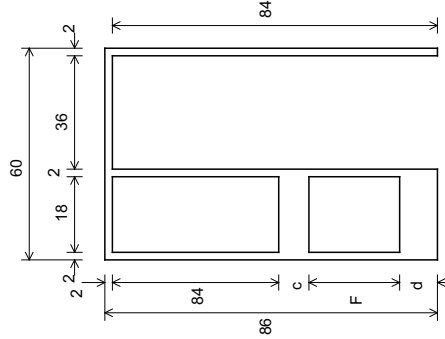

Elev C (L)

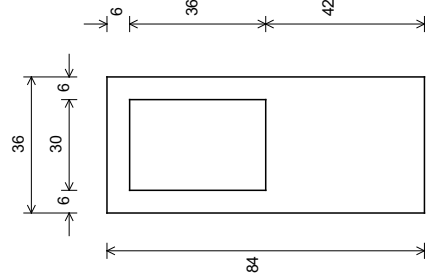

Elev G

Central Florida Door and Hardware

222 Sunshine way, Melburn FL 345321
 Tel 647-222-2525 Fax 647-222-2526

Project: Melburn ROI Inc. office addition
 Architect: ABC Design Inc.
 General Contractor: Sunshine Contracting.
 Date prepared: Mar 14, 2008

Shop drawing

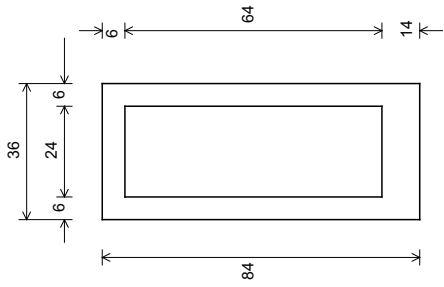

Elev FG

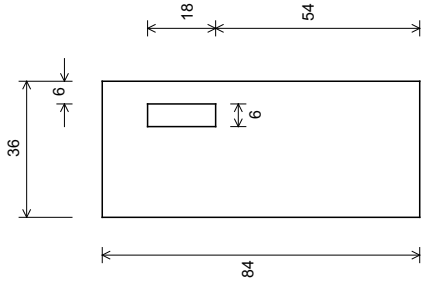

Elev NL

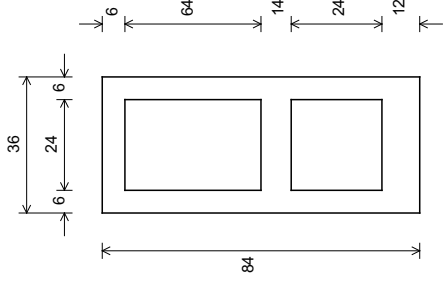

Elev 2G

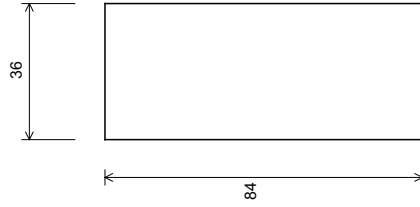

Elev F

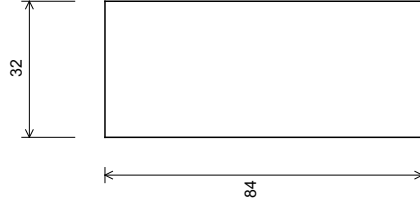

Elev F

Central Florida Door and Hardware

222 Sunshine way, Melburn FL 345321
 Tel 647-222-2525 Fax 647-222-2526

Project: Melburn ROI Inc. office addition
 Architect: ABC Design Inc.
 General Contractor: Sunshine Contracting.
 Date prepared: Mar 14, 2008

Shop drawing

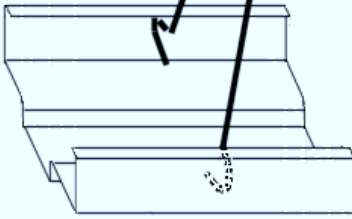

masonry (MA)

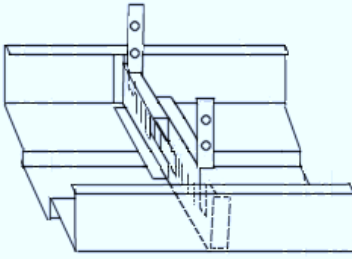

drywall (DW)

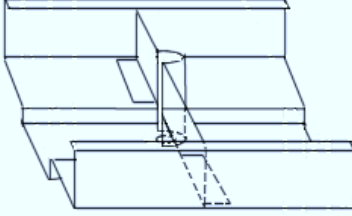

existing masonry anchor (EMA)

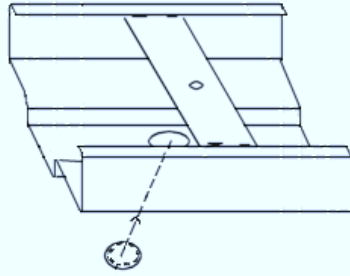

strap and plug (SP)

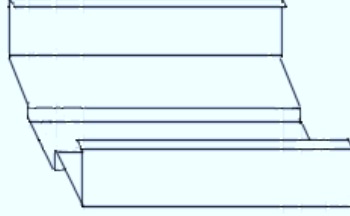
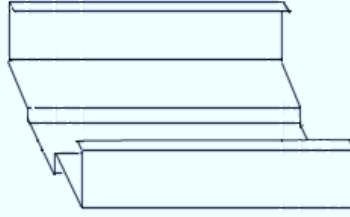

Ancr Diagram

Central Florida Door and Hardware

222 Sunshine way, Melburn FL 345321
Tel 647-222-2525 Fax 647-222-2526

Project: Melburn ROI Inc. office addition
Architect: ABC Design Inc.
General Contractor: Sunshine Contracting.
Date prepared: Mar 14, 2008

Shop drawing

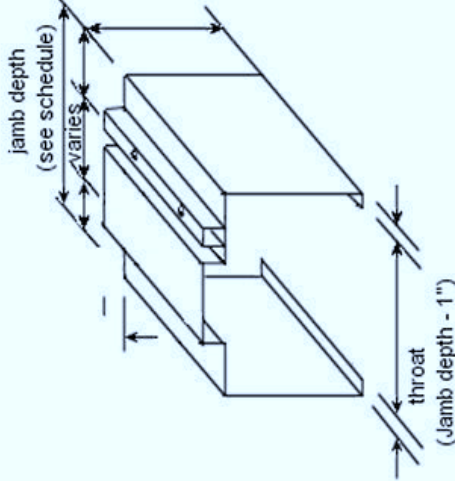
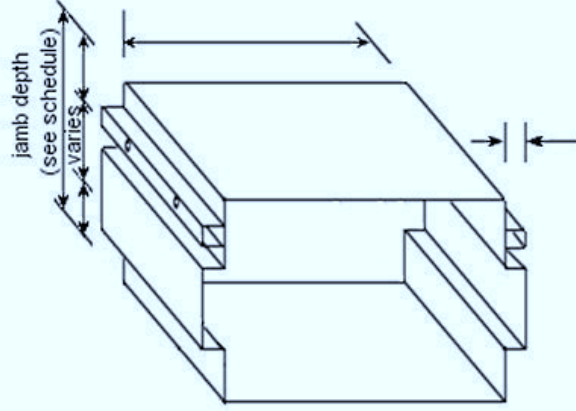
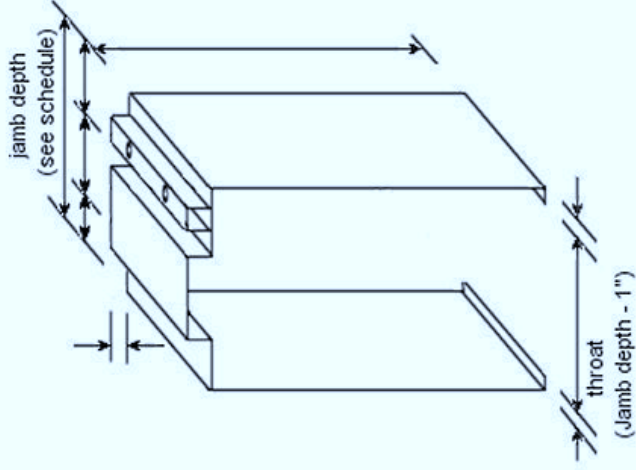
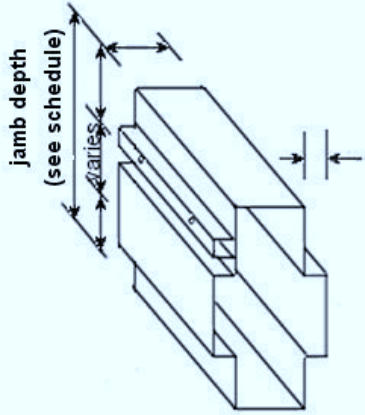
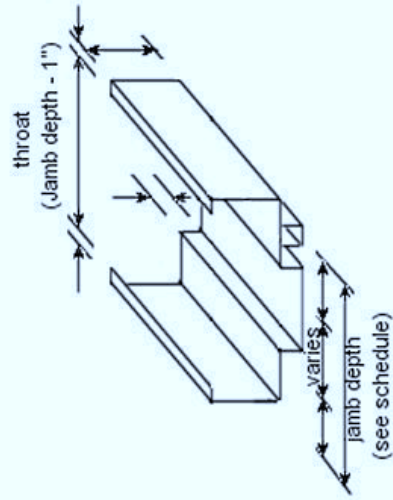

Section Diagrams

Central Florida Door and Hardware

222 Sunshine way, Melburn FL, 345321
 Tel 647-222-2525 Fax 647-222-2526

Project: Melburn ROI Inc. office addition
 Architect: ABC Design Inc.
 General Contractor: Sunshine Contracting.
 Date prepared: Mar 14,2008

Shop drawing

Hardware List

Date: Mar 14,2008
Customer: Sunshine Contracting.
Project: Melburn ROI Inc. office addition
Architect: ABC Design Inc.
Our rep: Gerry Muller
Our reference: Job #29
Prepared by: Gerris admin 2

Abbreviations

Dr.= door
Fr.= frame
Anch.= anchor
Ga.= guage
Hcomb.= honeycomb core
Poly= polystyrene core
Wd.= wood (door)
Hm.= hollow metal
Ps. = pressed steel

Finish codes

605 Bright brass
626 Dull chrome
625 Bright chrome
609 Dull brass, oxidized
630 Dull stainless steel

Heading # 1

1 single door # 101 - existing building to corridor 101 90-LHR
 36 X 84 X 1 3/4 HM LS18 Door X HM Frame
 .75hr Label

1	Continuous hinge	SL-11 83"	AL	SEL
1	Latchset	AL10S SAT 10-025	626	Sch
1	Closer	4140 H-Cush	689	Lcn
1	Floor Stop	CDH212	C26D	CDH
1	Kick Plate	CDH92A 8 x 34.5	C32D	CDH

Note: undersize door 3/16 for SL-11 continuous hinge

Heading # 2

1 single door # 102 - corridor 101 to office 102 90-LH
 1 single door # 103 - Corridor 101 to office 103 90-RH
 1 single door # 104 - Corridor 101 to office 104 90-LH
 1 single door # 105 - Corridor 101 to office 105 90-RH
 1 single door # 106 - Corridor 101 to office 106 90-LH
 1 single door # 107 - Corridor 101 to office 107 90-RH
 36 X 84 X 1 3/4 oak A25 Door X HM Frame

18	Hinge	BB1279 4.5 x 4	C26D	Hager
6	Lock Set	AL53PD SAT 10-025	626	Sch
6	Floor Stop	CDH212	C26D	CDH

Heading # 3

1 single door # 109 - Corridor 108 to lunch room 108 90-LH
 36 X 84 X 1 3/4 oak A25 Door X HM Frame

3	Hinge	BB1279 4.5 x 4	C26D	Hager
1	Latchset	AL10S SAT 10-025	626	Sch
1	Floor Stop	CDH212	C26D	CDH

Heading # 4

1 single door # 110 - corridor 108 to mens restroom 110 90-LH
 1 single door # 111 - corridor 108 to womens restroom 111 90-RH
 36 X 84 X 1 3/4 oak A25 Door X HM Frame

6	Hinge	BB1279 4.5 x 4	C26D	Hager
2	Pull	CDH5109-1	C32D	CDH
2	Push Plate	CDH93A 5 x 20	C32D	CDH
2	Closer	1460	689	Lcn
2	Floor Stop	CDH212	C26D	CDH
2	Kick Plate	CDH92A 8 x 34.5	C32D	CDH

Heading # 5

1 single door # 112 - Corridor 108 to storage 112 90-LH
 32 X 84 X 1 3/4 oak A25 Door X HM Frame
 .75hr Label

3	Hinge	BB1279 4.5 x 4	C26D	Hager
1	Lock Set	AL80PD SAT 10=025	626	Sch
1	Floor Stop	CDH212	C26D	CDH

Heading # 6

1 pair doors # 113 - Corridor 108 to boardroom 113 90-LHA/RH
 36 X 84 X 1 3/4 oak A25 Door
 36 X 84 X 1 3/4 oak A25 Door X HM Frame

6	Hinge	BB1279 4.5 x 4	C26D	Hager
2	Pull	CDH5109-1	C32D	CDH
2	Push Plate	CDH93A 5 x 20	C32D	CDH
2	Closer	1460	689	Lcn
2	Floor Stop	CDH212	C26D	CDH
2	Kick Plate	CDH92A 8 x 34.5	C32D	CDH

Heading # 7

1 single door # 114 - Corridor 108 to exterior

90-RHR

36 X 84 X 1 3/4 HM LS18 Door X HM Frame

3	Hinge	BB1168 4.5 x 4 NRP	630	Hager
1	Exit Device	22EO	689	Vd
1	Closer	4140 H-Cush	689	Lcn
1	Sweep	W13S/36	AL	PK
1	Threshold	CT10/36	AL	PK
1	Weatherstrip	W2/17	AL	PK

Hardware summary

1	- Continuous hinge * SL-11 83" * AL	SEL
1	- Weatherstrip * W2/17 * AL	PK
1	- Exit Device * 22EO * 689	Vd
1	- Threshold * CT10/36 * AL	PK
2	- Latchset * AL10S SAT 10-025 * 626	Sch
36	- Hinge * BB1279 4.5 x 4 * C26D	Hager
3	- Hinge * BB1168 4.5 x 4 NRP * 630	Hager
1	- Lock Set * AL80PD SAT 10=025 * 626	Sch
5	- Kick Plate * CDH92A 8 x 34.5 * C32D	CDH
2	- Closer * 4140 H-Cush * 689	Lcn
4	- Push Plate * CDH93A 5 x 20 * C32D	CDH
4	- Closer * 1460 * 689	Lcn
1	- Sweep * W13S/36 * AL	PK
4	- Pull * CDH5109-1 * C32D	CDH
6	- Lock Set * AL53PD SAT 10-025 * 626	Sch
13	- Floor Stop * CDH212 * C26D	CDH

Central Florida Door and Hardware

222 Sunshine way, Melburn FL, 345321 Tel 647-222-2525 Fax 647-222-2526

Shipping bill #29-1

Date: Mar 22,2008
Customer: Sunshine Contracting.
Project: Melburn ROI Inc. office addition
Site address: 222 22 St. W, Melbourn FL.
Contact: Jack Nicholson
Phone: 222-222-2456
Prepared by: Gerry Muller

Hardware (PO: 2591)

- 3 1580 - Hinge * BB1168 4.5 x 4 NRP * 630
- 1 2000 - Closer * 4140 H-Cush * 689
- 1 2002 - Exit Device * 22EO * 689

Doors (PO: 2589 2590)

- 1 Custom - 36 * 84 * 1 3/4 * HM * PolyS * 161 * NL * LS18 * RHR * (Opening: 114)

Frames, screens, borrowed lights (PO: 2589 2590)

- 1 Custom - 40 * 86 * 5 3/4 * HM * A AS16 * LHR * .75hr * Strap anchor LHR Frame (Opening: 101)
- 1 Custom - 60 * 86 * 5 3/4 * HM * C (L) AS16 * LH * * Drywall Clips LH Frame (Opening: 102)
- 1 Custom - 60 * 86 * 5 3/4 * HM * C (L) AS16 * RH * * Drywall Clips RH Frame (Opening: 103)
- 1 Custom - 60 * 86 * 5 3/4 * HM * C (L) AS16 * LH * * Drywall Clips LH Frame (Opening: 104)
- 1 Custom - 60 * 86 * 5 3/4 * HM * C (L) AS16 * LH * * Drywall Clips LH Frame (Opening: 106)
- 1 Custom - 60 * 86 * 5 3/4 * HM * C (L) AS16 * RH * * Drywall Clips RH Frame (Opening: 105)
- 1 Custom - 60 * 86 * 5 3/4 * HM * C (L) AS16 * RH * * Drywall Clips RH Frame (Opening: 107)
- 1 Custom - 40 * 86 * 5 5/8 * HM * A DW18 * LH * * LH Frame (Opening: 109)
- 1 Custom - 40 * 86 * 5 5/8 * HM * A DW18 * LH * * LH Frame (Opening: 110)
- 1 Custom - 40 * 86 * 5 5/8 * HM * A DW18 * RH * * RH Frame (Opening: 111)
- 1 Custom - 36 * 86 * 5 5/8 * HM * A DW18 * LH * .75hr * LH Frame (Opening: 112)
- 1 Custom - 96 * 86 * 5 3/4 * HM * D (R) DBL AS16 * LHA/RH * * Drywall Clips LHA/RH Frame (Opening: 113)
- 1 Custom - 40 * 110 * 8 3/4 * HM * TRA AS16 * RHR * * Wire Masonry RHR Frame (Opening: 114)

Miscellaneous

Must be on jobsite prior to 12:00.

Received by: _____ Date: _____

All goods deemed received in proper order.



Central Florida Door and Hardware

222 Sunshine way, Melburn FL, 345321 Tel 647-222-2525 Fax 647-222-2526

Sunshine Contracting.

555 22 St.
Orlando, FL 458742

Date: Mar 14,2008

Invoice #:

Job/Issue: 29-1

Customer PO: 2591

Project: Melburn ROI Inc. office addition

Qty	Type	Op#	Description
3	Hardware		1580 - Hinge * BB1168 4.5 x 4 NRP * 630
1	Hardware		2000 - Closer * 4140 H-Cush * 689
1	Hardware		2002 - Exit Device * 22EO * 689
			Sub total: \$ 562.50
			County tax(4.00%): \$ 22.50
			Grand total: \$ 585.00

Terms and conditions

Full amount due withing 30 days.

2% discount for payment within 5 days from invoice date.

Notes

This invoice fits into a standard window envelope.

You also have the option of printing line item pricing when required.



Central Florida Door and Hardware

222 Sunshine way, Melburn FL, 345321 Tel 647-222-2525 Fax 647-222-2526

Invoice #:

Job/Issue: 29-1

Customer PO: 2589

Project: Melburn ROI Inc. office addition

Qty	Type	Op#	Description
1	Door	114	Custom - 36 * 84 * 1 3/4 * HM * PolyS * 161 * NL * LS18 * RHR *
1	Frame	101	40 * 86 * 5 3/4 * HM * A AS16 * LHR * .75hr * Strap anchor
1	Screen	102	60 * 86 * 5 3/4 * HM * C (L) AS16 * LH * * Drywall Clips
1	Screen	103	60 * 86 * 5 3/4 * HM * C (L) AS16 * RH * * Drywall Clips
1	Screen	104	60 * 86 * 5 3/4 * HM * C (L) AS16 * LH * * Drywall Clips
1	Screen	106	60 * 86 * 5 3/4 * HM * C (L) AS16 * LH * * Drywall Clips
1	Screen	105	60 * 86 * 5 3/4 * HM * C (L) AS16 * RH * * Drywall Clips
1	Screen	107	60 * 86 * 5 3/4 * HM * C (L) AS16 * RH * * Drywall Clips
1	Frame	109	40 * 86 * 5 5/8 * HM * A DW18 * LH * *
1	Frame	110	40 * 86 * 5 5/8 * HM * A DW18 * LH * *
1	Frame	111	40 * 86 * 5 5/8 * HM * A DW18 * RH * *
1	Frame	112	36 * 86 * 5 5/8 * DW18 * HM * A * .75hr LH
1	Screen	113	96 * 86 * 5 3/4 * HM * D (R) DBL AS16 * LHA/RH * * Drywall Clips
1	Frame	114	40 * 110 * 8 3/4 * HM * TRA AS16 * RHR * * Wire Masonry

Sub total:	\$ 2,904.83
County tax(4.00%):	\$ 116.19
Grand total:	\$ 3,021.02

Terms and conditions

Full amount due withing 30 days.

2% discount for payment within 5 days from invoice date.

Notes

This invoice fits into a standard window envelope.

You also have the option of printing line item pricing when required.